

nox medical

# nox c1

MANUAL

US Manual

## Nox C1 US Manual

Version 2.0

Latest Revision: March 2021

Copyright © 2021

Nox Medical - All rights reserved

### **Manufactured by:**

Nox Medical ehf

Katrinartuni 2

IS - 105 Reykjavik

Iceland

Website: [www.noxmedical.com](http://www.noxmedical.com)

# nox medical

For distributor information go to:

[www.noxmedical.com](http://www.noxmedical.com)

### **Copyright Notice**

No part of this publication may be reproduced, transmitted, transcribed, stored in a retrieval system, or translated into any language or computer language, in any form, or by any means: electronic, mechanical, magnetic, optical, chemical, manual, or otherwise, without the prior written authorization from Nox Medical.

### **License Notice**

The Nox C1 Access Point uses software components covered by open source licenses. Licenses covering these software components are available on the Nox Medical website:

[www.noxmedical.com/products/nox-c1](http://www.noxmedical.com/products/nox-c1)

---

**TABLE OF CONTENTS**

Table of Contents .....	3
Introduction .....	5
Intended Use .....	5
Contraindications .....	5
Scope .....	5
Instructions for Operators.....	6
Warnings and Cautions for Use.....	6
Nox C1 AcCess POINT Description .....	8
Nox C1 Access Point Interface .....	8
Operating Nox C1 ACCESS POINT .....	11
Connect to DC Power .....	11
Nox C1 Access Point Status .....	12
Nox C1 Access Point Analog Inputs .....	13
Nox C1 Access Point Differential Pressure Sensor .....	14
Nox C1 Access Point Serial Inputs .....	15
Nox C1 Access Point USB Inputs.....	15
Nox C1 Access Point Ambient Light Sensor.....	16
Nox C1 ACCESS POINT Network Configuration .....	18
Default Factory Configuration .....	18
Factory Reset.....	18
Nox C1 Access Point Setup.....	19
Nox Sleep System Network Overview .....	19
Maintenance .....	21
Compatible Devices, Sensors and Accessories.....	24
Specifications .....	27
Nox C1 Access Point .....	27

---

Power Supply.....28

Bluetooth® 5.0 Dongle .....28

Regulatory Information..... 30

Performance Testing and Validation Summary.....30

Nox C1 Classification .....30

Description of Symbols and Labels.....30

Bluetooth® Wireless Technology .....33

Electromagnetic Compatibility (EMC) Information .....33

## INTRODUCTION

Congratulations on choosing the Nox C1 Access Point. The Nox C1 is a part of the Nox Sleep System and has the main function to measure, receive, and stream physiological signals during online configuration of the Nox Sleep System. The Nox C1 Access Point is able of communicating with Nox A1 Recorder and Noxturnal App over Bluetooth® link and with the Noxturnal US PC software over Ethernet to allow configuration of the Nox devices and streaming of online data.

## Intended Use

The Nox Sleep System is used as an aid in the diagnosis of different sleep disorders and for the assessment of sleep.

The Nox Sleep System is used to measure, record, display, organize, analyze, summarize and retrieve physiological parameters during sleep and wake.

The Nox Sleep System allows the user to decide on the complexity of the study by varying the number and types of physiological signals measured.

The Nox Sleep System allows for generation of user/pre-defined reports based on subject's data.

The users of the Nox Sleep System are medical professionals who have received training in the areas of hospital/clinical procedures, physiological monitoring of human subjects, or sleep disorder investigation.

The intended environments are hospitals, institutions, sleep centers, sleep clinics, or other test environments, including patient's home.

- ▶ Note: The Nox C1 Access Point is only needed during online setup of the Nox Sleep System and never used during ambulatory setup of the Nox Sleep System. The Nox C1 Access Point is thus not intended to be used in the home environment.

## Contraindications

The Nox Sleep System does not provide any alarms and is not intended to be used for continuous monitoring where failure to operate can cause injuries or death of the patient.

## Scope

This manual covers the instructions for the Nox C1 Access Point, and how to setup and operate the device. The Nox C1 Access Point is operated by the Noxturnal US PC software. For instructions on how to configure and operate the device from the Noxturnal US software refer to the Noxturnal US manual. The Noxturnal US software and detailed user instructions are provided in electronic form at: [support.noxmedical.com](http://support.noxmedical.com). For an online setup of the Nox Sleep System a Nox A1 recorder is also needed. For instructions on how to set up for online recording please refer to:

- Noxturnal US Manual
- Nox A1 US Manual
- Nox A1s US Manual

Throughout this manual, a Nox A1 recorder and Nox A1s recorder are collectively referred to as Nox A1 recorders.

## Instructions for Operators

This manual is only intended for professionals (healthcare professionals and service personnel) with relevant qualifications and skills.

## Warnings and Cautions for Use



- ▶ **Warning:** The Nox Sleep System is **NOT certified for continuous monitoring** where failure to operate can cause injuries or death of the patient.
- ▶ **Caution:** U.S. federal law restricts this device to sale by, or on the order of, a licensed medical practitioner.
- ▶ **Caution:** The Nox C1 Access Point complies with the international standard IEC 60601-1-2 for electromagnetic compatibility for medical electrical equipment and/or systems. That standard is designed to provide reasonable protection against harmful interference in a typical medical installation. However, because of the proliferation of radio-frequency transmitting equipment and other sources of electrical noise in healthcare and other environments, it is possible that high levels of interference due to close proximity or strength of source might disrupt the performance of the device, affecting recorded signals and therefore data analysis and resulting in possible incorrect treatment. Medical electrical equipment needs special precautions regarding Electromagnetic Compatibility (EMC), and needs to be installed and put into service according to the EMC information provided in the “Electromagnetic Compatibility (EMC) Information” section of this manual.
- ▶ **Warning:** Electromagnetic Interference (EMI) can be picked up by the analog channels of the Nox C1 Access Point, causing disturbed or altered signals to appear in the Noxturnal US software. This may affect data analysis and result in possible incorrect treatment.
- ▶ **Warning:** The use of accessories and cables other than those listed in this manual may result in increased emissions and/or decreased immunity of the Nox Sleep System and cause injuries to the operator/patient.
- ▶ **Warning:** The Nox C1 Access Points should not be used adjacent to or stacked with other equipment. If adjacent or stacked use is necessary, the device(s) should be observed to verify normal operation in the configuration in which it/they will be used and prevent abnormal operation which might cause injuries to the operator/patient.
- ▶ **Warning:** The Nox Sleep System may be interfered with by other equipment, even if that equipment complies with emission requirements of the CISPR (Special International Committee on Radio Interference) causing possible patient harm.
- ▶ **Warning:** The Nox C1 Access Point is not designed to give a specified degree of protection against harmful ingress of liquids. Do not autoclave or immerse the device in any kind of liquids. Ingress of liquids may result in electric shock.
- ▶ **Warning:** Only use United States Environmental Protection Agency (EPA) registered products for cleaning of the Nox C1 Access Point to prevent harm to the operator/patient.

- ▶ **Warning:** Do not use damaged equipment, sensors, or accessories. This may result in bad performance of the Nox Sleep System or patient/operator injury.
- ▶ **Warning:** There are no user serviceable parts inside the Nox C1 Access Point. The device should be serviced by authorized parties only. Service performed by non-authorized parties may affect data analysis and result in possible incorrect treatment. The warranty is void if the Nox C1 Access Point is opened.
- ▶ **Warning:** No modification of the Nox C1 Access Point is allowed. Un-authorized modifications may affect data analysis and result in possible incorrect treatment.
- ▶ **Warning:** External equipment and all auxiliary devices intended for connection to signal input, signal output or other connectors shall comply with the relevant product safety standards, e.g. IEC 60950-1 for IT equipment and the IEC 60601 series for medical electrical equipment, to prevent electric shocks. In addition, all such combinations – systems – shall comply with the safety requirements stated in the general standard IEC 60601-1, edition 3/3.1, clause 16. Any equipment not complying with the leakage current requirements in IEC 60601-1 shall be kept outside the patient environment, i.e. at least 1.5 m from the patient support. Any person who connects external equipment to signal input, signal output or other connectors has formed a system and is therefore responsible for the system to comply with the requirements. In if doubt, contact a qualified medical technician or your local representative.
- ▶ **Caution:** After connecting a new auxiliary signal to the Nox C1 Access Point connectors OR after modifying the connection of the auxiliary signals OR after changing the mode of the auxiliary devices signal output, always verify the correct setup by performing an actual recording, making the auxiliary device create a known signal, and monitoring the appearance and values measured in the Noxturnal US software, in order to prevent signals that would lead to incorrect interpretation and possible incorrect treatment.
- ▶ **Warning:** All the auxiliary devices connected to the Nox C1 Access Point should be powered from a single power strip to ensure a common ground, avoid ground potential difference skewing or disturbing the signals and thus prevent possible incorrect treatment.
- ▶ **Warning:** Only use power supply **FRIWO MP115 Medical-7555M/12** with the Nox C1 Access Point. The use of an incorrect power supply may result in electric shock or cause the device to overheat, which may result in patient/operator harm.
- ▶ **Warning:** The USB channels, serial channels, and analog channels on the Nox C1 Access Point are signal input/output (SIP/SOP) auxiliary ports **NOT TO BE CONNECTED IN DIRECT GALVANIC CONNECTION** to the patient. This may result in electric shock.



Please read the user instructions carefully before initial use, especially sections marked with an exclamation mark.

## NOX C1 ACCESS POINT DESCRIPTION

The Nox C1 is a Bluetooth® access point. It receives Bluetooth data stream from a Nox A1/Nox A1s Recorder, has input ports for receiving of signals originating from various auxiliary devices and internal sensors for ambient light measurement and pneumotachography. The measured/received signals are processed within the Nox C1 Access Point before they are streamed forward to the Noxturnal US software over Ethernet.

The Nox C1 Access Point channels and built-in capabilities include the following:

- 12 analog channels; for recording of DC signals from auxiliary devices
- 2 USB channels; e.g. to connect a Bluetooth® 5.0 dongle to support wireless connectivity allowing the device to receive signals from the Nox A1s recorder.
- 2 serial channels; for recording of serial signals from auxiliary devices
- 2 pressure sensor channels; e.g. for recording of patient airflow at the proximal airway when using a PAP device
- Built-in ambient light sensor
- Built-in Bluetooth® 4.0 module; to support wireless connectivity allowing the device to receive signals from the Nox A1 Recorder

The Nox C1 Access Point is also equipped with an Ethernet input; to support connection of the device to an Ethernet network for streaming of data and commands between the device and a remote computer.

Furthermore, the Nox C1 Access Point communicates with the Nox A1 Recorder and Noxturnal App over Bluetooth link and with the Noxturnal US PC software over Ethernet to allow configuration of the Nox devices and streaming of data.

The Nox C1 Access Point is powered by a medical grade power supply providing medical grade isolation from mains.

## Nox C1 Access Point Interface

The Nox C1 Access Point interface consists of an indicator light (LED) for device status, ambient light sensor, analog channel inputs, Ethernet cable input, factory reset button, USB inputs, serial inputs, differential pressure sensor inputs and power supply connector.

The next figure shows the top view of the Nox C1 Access Point, showing the device's indicator light - LED (1) and the ambient light sensor (2). For device status indicated with the LED, refer to the "Device Status" section.





The figure below shows the front view of the Nox C1 Access Point, showing the six analog inputs, labelled DC IN 1-12.



The figure below shows the rear of the Nox C1 Access Point, showing the six inputs available. Refer to the table below for input definition.



The following table lists the Nox C1 Access Point inputs and the corresponding input labeling.

NUMBER	FUNCTION	INPUT/SENSOR LABEL
1	Indicator light for device status	No label on device
2	Ambient light sensor	No label on device
3	Analog inputs	DC IN 1-12
4	Ethernet cable input	LAN
5	Factory reset button	No label on device
6	USB inputs	USB
7	Serial inputs	1 COM 2
8	Differential pressure sensor inputs	+ PRES -
9	DC power supply connector	-----

## OPERATING NOX C1 ACCESS POINT

The Nox C1 Access Point is only intended to be operated by professionals (healthcare professionals and service personnel) with relevant qualification in hospitals, institutions, sleep centers, sleep clinics or other test environment, not including the patient's home.

### Connect to DC Power



- ▶ **Warning:** Only use power supply FRIWO MP115 Medical-7555M/12 with the Nox C1 Access Point. The use of an incorrect power supply may result in electric shock or cause the device to overheat, which may result in patient/operator harm.

The Nox C1 Access Point is powered by **FRIWO MP115 Medical-7555M/12**, a specific medical grade power supply rated with operating voltage of 12 volts and providing medical grade isolation from mains. Connect the power supply into the DC power supply connector on the rear of the device and have the applicable regional adapter connected to the power supply.



Verify that the LED indicator light on top of the Nox C1 Access Point starts blinking amber immediately after connection of the power supply and starts blinking green when the startup sequence of the device is completed, and the Nox C1 Access Point is available for configuration.

### [FRIWO MP115 Medical-7555M/12 \(FW7555M/12\)](#)

The medical grade power supply FRIWO MP115 Medical-7555M/12 is the only power supply that should be used with the Nox C1 Access Point to ensure safe and effective device operation. The LED indicator on the power supply is the operating indicator. For detailed user instructions, product specifications and regulatory information please refer to the Nox Medical web page.



- ▶ **Caution:** In the case of visible damages on the housing or on the cord do not use the power supply.
- ▶ **Warning:** The device should never be operated or even stored at places listed below, because this could lead to operating failures:

- Places, which are heavily exposed to moisture or where water condensing may occur
- Places, which are exposed to special environmental conditions
- Places, which are subject to constant vibrations
- Places, which are subject to high temperature fluctuations
- Outdoors
- ▶ **Caution:** Always disconnect the power supply from mains during lightning storms or when not in use.
- ▶ **Caution:** The power supply itself is the disconnect device. Never use the cord to pull the power supply from the mains.
- ▶ **Warning:** The power supply is maintenance free. It must not be opened. (Risk of electrical shock).
- ▶ **Warning:** A modification of the power supply is not allowed.
- ▶ **Warning:** The device may only be repaired by authorized personnel.
- ▶ **Warning:** Remove from mains before cleaning. Do not clean with detergents. Clean only with a dry cloth.
- ▶ **NOTE:** The power supply unit is intended for supplying end medical product by its output voltage.
- ▶ **Warning:** The unit shall not be used for use in an oxygen rich environment.
- ▶ **Warning:** The unit it is not intended to be used with flammable anesthetics and not intended for use in conjunction with flammable agents.

## Nox C1 Access Point Status

The Nox C1 Access Point has a built-in LED for device status indication. The LED is located on the top panel of the device. Refer to the table below for a description of the different states of the Nox C1 Access Point indicated with the LED.

Status Light	Description
Off	▶ Nox C1 is not connected to power and is turned off
Blinking amber	▶ Nox C1 is connected to power and is completing the startup sequence
Blinking green	▶ Nox C1 is connected to power and ready to use. A recording is not running
Solid green	▶ A recording is running
Solid amber	▶ Firmware error indication, Nox C1 is not functional
	▶ Nox C1 should be factory reset (refer to section “Factory Reset”)

Alternating green and amber ▶ Firmware upgrade/factory reset is running

The LED brightness will automatically dim during a recording to ensure patient comfort.

**Nox C1 Access Point Analog Inputs**

 ▶ **Warning:** The analog channels on the Nox C1 Access Point are signal input/output (SIP/SOP) auxiliary ports not to be connected in direct galvanic connection to the patient. This could result in electric shock.

The Nox C1 Access Point is equipped with 12 analog channels suitable for collecting of DC signals from auxiliary devices. The channels are collected on 6 inputs, labeled DC IN from 1 to 12 on the top of the device. The analog inputs which are 3.5 mm female stereo jack and yields 2 channels each. The voltage range allows interfacing signals from -5 V to +5 V.

Auxiliary devices can be connected to the Nox C1 Access Point analog inputs using a standard 3.5 mm male stereo jack or a 3.5 mm male mono jack, such as the Sinbon C1 Splitter Cable (562014). The Sinbon C1 Extension cable (562012) can be used for extension purposes.



The 12 analog channels offered by the Nox C1 Access Point have six inputs labeled DC IN from 1 to 12, see the figure above. The table below addresses the channel identification.

Analog Inputs	Analog Channels 1-12
Analog Input 1 and 2	Channel 1
	Channel 2
Analog Input 3 and 4	Channel 3
	Channel 4
Analog Input 5 and 6	Channel 5
	Channel 6
Analog Input 7 and 8	Channel 7
	Channel 8
Analog Input 9 and 10	Channel 9
	Channel 10

Analog Input 11 and 12	Channel 11
	Channel 12

The table below lists available commercial connectors that can be used for connection to the Nox C1 Access Point analog channel inputs.

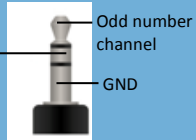
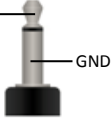
Connector Type	Channel Identification	
3,5 mm male stereo jack	▶ A stereo jack can carry two analog channels (e.g. channels 1 and 2)	
3,5 mm male mono jack	▶ A mono connector can carry one analog channel (e.g. channel 1)	

For the analog channel specifications refer to the “Specifications” section. Please refer to the Noxturnal US manual for more information on how to configure and license the analog channels.

Refer to the “Compatible Devices, Sensors and Accessories” section regarding the types of Auxiliary Devices that have been validated with the Nox C1 Access Point.

### Nox C1 Access Point Differential Pressure Sensor

To setup the Nox C1 Access Point for a recording of patient airflow at the proximal airway when using a PAP device, connect two Nox filter tube connectors to the differential pressure sensor inputs on the rear of the device, labelled + PRES -. The differential pressure sensor inputs are designed to fit directly with the filter tube connector interface from Nox Medical. The figure below shows the Nox filter tube connectors connected to the differential pressure sensor inputs.

For the differential pressure sensor specifications refer to the “Specifications” section.

Refer to the “Compatible Devices, Sensors and Accessories” section regarding the types of Pneumoflow Sensors that have been validated with the Nox C1 Access Point.



## Nox C1 Access Point Serial Inputs



- ▶ **Warning:** The serial channels on the Nox C1 Access Point are signal input/output (SIP/SOP) auxiliary ports not to be connected in direct galvanic connection to the patient. This could result in electric shock.

To record signals from auxiliary devices over a serial connection connect a standard serial cable with a 3.5 mm male stereo jack carrying the serial signal to a COM input (such as the Sinbon C1 Serial Cable (562013)) on the rear of the Nox C1 Access Point. The figure below shows the rear of the device, where the serial inputs are located. The serial inputs are labelled 1 COM 2. For the serial input specifications refer to the “Specifications” section.

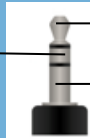

Connector Type	Channel Identification	
3,5 mm male stereo jack	<ul style="list-style-type: none"> <li>▶ The COM stereo jacks carry one serial channel each with TxD, RxD and GND at RS232 levels.</li> </ul>	

Refer to the “Compatible Devices, Sensors and Accessories” section regarding the types of Auxiliary Devices and accessories that have been validated with the Nox C1 Access Point.

## Nox C1 Access Point USB Inputs



- ▶ **Warning:** The USB channels on the Nox C1 Access Point are signal input/output (SIP/SOP) auxiliary ports not to be connected in direct galvanic connection to the patient. This could result in electric shock.
- ▶ The minimum distance between the user and/or any bystander and the radiating structure of the Bluetooth® Dongle is 20 cm.

The USB inputs are on the rear of the device. The figure below shows the rear of the device, where the USB inputs are located. The USB inputs are labelled USB. For the USB input specifications refer to the “Specifications” section.



If using the Nox A1s recorder, the Bluetooth® 5.0 dongle should be connected to the USB ports as shown on the picture below to allow the device to receive signals from the Nox A1s recorder. It doesn't matter which of the USB port is used.

Before inserting the Bluetooth® 5.0 dongle for the first time it is important to do a factory reset on the USB dongle and to make sure the Nox C1 is on the newest version of firmware. For more information refer to details steps on the Nox Medical support page ([support.noxmedical.com](http://support.noxmedical.com)).

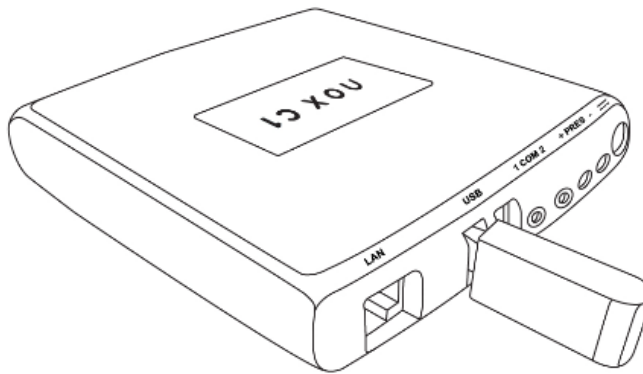

The functionality of the Bluetooth Dongle will be enabled automatically after connection during startup of the Nox C1.

### Nox C1 Access Point Ambient Light Sensor

The Nox C1 Access Point has a built-in ambient light sensor located on the top panel of the device; see the figure below (1).







The light sensor can be used for light detection in the patient room. For the light sensor to work properly make sure not to cover the light sensor on the device. For the light sensor specifications refer to the “Specifications” section.

## NOX C1 ACCESS POINT NETWORK CONFIGURATION

### Default Factory Configuration

The factory state of the Nox C1 Access Point is listed in the table below.

Nox C1 Network Configuration	Details
DHCP server	DHCP pool: 192.168.101.64 - 192.168.101.127
Static IP address	192.168.101.10
Universal Plug and Play (UPnP) discovery	Networking protocol that permits the Nox C1 Access Point to be discovered on a network

The Nox C1 Access Point network configuration can be managed through the Noxturnal US software. Please refer to the Noxturnal US manual for instructions on how to configure the Nox C1 Access Point network settings.

### Factory Reset

To reset the Nox C1 Access Point to factory state follow the instructions below:

1. Unplug the power supply from the Nox C1 Access Point
2. Reset the device by performing the following:
  - i. Use a sharp pin (such as a toothpick) and press and hold the reset button on the rear of the device (see figure below)
  - ii. While pressing the reset button connect the power supply to the device
  - iii. You can release the reset button once you see the device LED alternating between green and amber
3. The LED on the top panel will blink amber while the device is completing the startup sequence
4. After approximately 60 seconds the LED starts blinking green. This indicates that the device has been reset to factory defaults and will have the network configuration listed in the “Default Factory Configuration” section



► NOTE: Do not use a metallic item to perform the factory reset.

## NOX C1 ACCESS POINT SETUP

### Nox Sleep System Network Overview

Before setting up the Nox C1 Access Point on the network read the following.



- ▶ Note: The Nox C1 Access Point should be connected to a 10/100 IP-enabled Ethernet network to transfer configuration and study data between the Nox C1 Access Point and the operator workstation running the Noxturnal US software. The Nox C1 Access Point replies to Internet control message protocol (ICMP) echo requests and can be discovered with the Universal Plug and Play (UPnP) protocol. The Nox C1 Access Point listens on TCP port 8080 for configuration requests and on port 8888 for UPnP discovery requests.
- ▶ Note: Any study data collected during a network outage is discarded and the user will be notified in Noxturnal US if such an event occurs.
- ▶ Note: If the Nox C1 Access Point is connected to a shared network please make sure that any device connected to the network does not cause network congestion reducing the operational integrity of the Nox C1 Access Point.

To ensure steady operation of the Nox Sleep System please follow the recommended system setup below.

- ▶ Use a separate local area network (LAN) for each Nox C1 Access Point and a computer running the Noxturnal US software, i.e. each patient room that includes the Nox C1 Access Point should be on a separate network.
- ▶ Use a separate Nox C1 Access Point for each Nox A1 Recorder to be used.  
Use a separate computer running Noxturnal US for each Nox C1 Access Point.

The table below describes the setup of the control room where the computer with Noxturnal US installed is located.

<b>Control Room</b>	
<b>Item</b>	<b>Connection</b>
PC	Connected to the same network as the Nox C1 Access Point with a network cable
Noxturnal US	Installed on PC

The table below describes the setup of the patient room where the patient is sleeping during a sleep study.

Patient Room			
Item Name	Description	Function	Setup/Connection
Nox C1 Access Point	Bluetooth access point with analog and serial inputs and built in light sensor and differential pressure sensor	<ul style="list-style-type: none"> <li>▶ Data transfer received from Nox A1 Recorder over Bluetooth connection and forwarded to Noxturnal US via Ethernet</li> <li>▶ Commands received from Noxturnal US via Ethernet and forwarded to Nox A1 Recorder using Bluetooth connection</li> <li>▶ Data transfer received from auxiliary devices connected to analog and/or serial inputs and forwarded to Noxturnal US via Ethernet</li> </ul>	Located in the patient room. Connected to the same LAN as the PC running the Noxturnal US software
Nox A1 Recorder and patient applied sensors	Recording device that may be configured for different types of sleep studies.	Records physiological signals from built-in and attached sensors and pulse oximeter data over Bluetooth link.	Device and sensors are applied to the patient.
Medical Auxiliary Devices	Supported medical devices/medical devices that fits the analog input channel specifications of the Nox C1 Access Point.	Depends on the auxiliary device being used	The applicable connection cable connected to the analog/serial input on the Nox C1 Access Point.
Noxturnal App	Android App	Can be used to connect to Online Rooms, review signal traces and perform bio calibration and impedance check. Can also be used to start and stop recordings	Set the App to Online Mode and connect to the applicable online room

The Nox C1 Access Point is operated by the Noxturnal US software. For instructions on how to configure and operate the Nox C1 Access Point and Nox A1 Recorder from the Noxturnal US software refer to the Noxturnal US manual.

## MAINTENANCE

The Nox Sleep System is only intended to be maintained by professionals (healthcare professionals and service personnel) with relevant qualifications and skills.

The Nox C1 Access Point and accessories should be stored in a clean, dry place.

Handle the Nox C1 Access Point with care and protect it against mechanical shocks, dirt, and liquids. The device is not waterproof or splash proof.

To update the Nox C1 firmware you will need the Noxturnal US software running on a computer which is on the same network as the Nox C1 Access Point. Please refer to the Noxturnal US manual for more information on how to perform this task.

No regular testing of the Nox C1 Access Point is needed.

The service life of the Nox C1 Access Point and the FRIWO MP115 Medical-7555M/12 power supply is 5 years or the equivalent of 1000 studies in total, given that 200 studies are performed in a year.

### Environmental Conditions



- ▶ Note: The environmental conditions listed below apply both for the Nox C1 Access Point and the accompanying FRIWO MP115 Medical-7555M/12 power supply.

Temperature	Operation: +5°C to +40°C (41°F to 104°F) Transport/Storage: -25°C to +70°C (-13°F to 158°F)
Relative Humidity	Operation: 15-90% (non-condensing) Transport/Storage: 10-95% (non-condensing)
Pressure	Withstands atmospheric pressures from 700 hPa to 1060 hPa

### Calibration

The Nox C1 Access Point is factory calibrated. No further calibration is needed.



- ▶ Warning: There are no user serviceable parts inside the Nox C1 Access Point. The device should be serviced by authorized parties only. Service performed by non-authorized parties may affect data analysis and result in possible incorrect treatment. The warranty is void if the Nox C1 Access Point is opened.
- ▶ Warning: No modification of the Nox C1 Access Point is allowed. Unauthorized modifications may affect data analysis and result in possible incorrect treatment.

## Cleaning



- ▶ Warning: The Nox C1 Access Point device is not designed to give a specified degree of protection against harmful ingress of liquids. Do not autoclave or immerse the device in any kind of liquids. Ingress of liquids may result in electric shock.
- ▶ Warning: In the United States of America, only use United States Environmental Protection Agency (EPA) registered products for disinfection of the Nox C1 Access Point to prevent harm to the operator/patient
- ▶ Note: The Nox C1 Access Point is NOT intended to be sterilized.
- ▶ Note: Regarding cleaning/disinfection and re-use of 3<sup>rd</sup> party components and 3<sup>rd</sup> party sensors refer to the applicable 3<sup>rd</sup> party accompanying instructions.
- ▶ Note: Soiled towelettes/cloths should be disposed of as biohazard material in accordance with federal, state, and local regulations.

As applicable, all reusable components should be cleaned immediately after use to prevent accumulation of residual soil and minimize soil transfer between patients.

### MATERIALS/EQUIPMENT:

- Endozime® AW Plus Hospital grade cleaner
- Lint-free cloths
- Gloves
- Soft bristle nylon brush (i.e. electrode brush, toothbrush, or nail brush)
- PDI Sani-Cloth Plus Germicidal Disposable Cloth or equivalent validated disinfectant\*

### CLEANING/DISINFECTING PROCEDURE:

1. Prepare a solution with the Endozime® AW Plus hospital grade cleaner
  - Follow the instructions accompanying the hospital grade cleaner
2. Dampen a lint-free cloth with the solution
  - Do not pour or spray any liquids on the Nox C1 Access Point
  - Do not allow any liquids to enter any openings on the Nox C1 Access Point
  - Avoid contact of the cleaning solution to the connectors
3. Wipe all surface areas thoroughly to remove all visible soil and contaminants. Wipe the device for at least 2 minutes. Use a soft bristle nylon brush if necessary.
4. Visually inspect the cleaned device to ensure no soil remains. Pay good attention to all junctions and details. Repeat steps 2 and 3 if necessary.
5. Allow the device to air dry completely before disinfection (minimum of 3 minutes)
6. For disinfection, take a new wipe of PDI Sani-Cloth Plus Germicidal Disposable Cloth or equivalent validated disinfectant\*
7. Wipe all surface areas of the device with the disinfectant for at least three minutes
  - If other disinfection materials are used than PDI Sani-Cloth Plus Germicidal Disposable Cloth make sure:
    - they are safe to use on metals and plastics
    - to read the instructions from the manufacturer regarding required contact time of the solution to provide sufficient disinfection

8. Allow the device to air dry completely before next use (minimum 1 minute)
9. Visually inspect the Nox C1 Access Point under adequate lighting conditions (and magnification if needed) to confirm that the cleaning/disinfection process has not damaged the device. Inspect for surface wear, discoloration, corrosion, or cracking\*\*

\* PDI Sani-Cloth Plus Germicidal Disposable Cloth are Environmental Protection Agency (EPA) registered product for disinfection of medical devices in the United States of America.

\*\* If any component damage occurs during cleaning process, contact Nox Medical immediately at [support@noxmedical.com](mailto:support@noxmedical.com). Do not attempt to use the Nox C1 Access Point until the device has been inspected and repaired by authorized Nox Medical personnel.

For cleaning of FRIWO MP115 Medical-7555M/12 power supply only use dry cloth. Do not clean with detergents.



- ▶ Warning: Remove the power supply from mains before cleaning. Do not clean the power supply with detergents. Clean only with a dry cloth

## Disposal

---

Follow local governing ordinances and recycling instructions regarding disposal or recycling of the Nox C1 Access Point and accessories.

## COMPATIBLE DEVICES, SENSORS AND ACCESSORIES



- ▶ **Warning:** Do not use damaged equipment, sensors, or accessories. This may result in bad performance of the device or patient/operator injury.
- ▶ **Warning:** External equipment and all auxiliary devices intended for connection to signal input, signal output or other connectors shall comply with the relevant product safety standards, e.g. IEC 60950-1 for IT equipment and the IEC 60601 series for medical electrical equipment, to prevent electric shocks. In addition, all such combinations – systems – shall comply with the safety requirements stated in the general standard IEC 60601-1, edition 3/3.1, clause 16. Any equipment not complying with the leakage current requirements in IEC 60601-1 shall be kept outside the patient environment i.e. at least 1.5 m from the patient support. Any person who connects external equipment to signal input, signal output or other connectors has formed a system and is therefore responsible for the system to comply with the requirements. If in doubt, contact a qualified medical technician or your local representative.
- ▶ **Caution:** After connecting a new auxiliary signal to the Nox C1 Access Point connectors OR after modifying the connection of the auxiliary signals OR after changing the mode of the auxiliary devices signal output, always verify the correct setup by performing an actual recording, making the auxiliary device create a known signal, and monitoring the appearance and values measured in the recording software, in order to prevent signals that would lead to incorrect interpretation and possible incorrect treatment.
- ▶ **Warning:** All the auxiliary devices connected to the Nox C1 Access Point should be powered from a single power strip to ensure a common ground, avoid ground potential difference skewing or disturbing the signals and thus prevent possible incorrect treatment.

The following table includes information on accessories, sensors and devices that have been validated with the Nox C1 Access Point.

The items listed below are Nox products and have been validated for use with the Nox C1 Access Point:

### NOX FILTER TUBE CONNECTORS

Type	Catalog Number
Nox Filter Tube Connector, 50 units	552110

### NOX SLEEP SYSTEM COMPONENTS

Type	Catalog Number
Nox A1 System Kit	513510
Nox A1 Recorder	561120



Noxturnal US	NA
Noxturnal US CD	539012
Noxturnal App	536210
Nox C1 Access Point	544021

## POWER SOURCE

Type	Catalog Number
FRIWO MP115 Medical-7555M/12	NA*

The items listed below are 3<sup>rd</sup> party products and have been validated for use with the Nox C1 Access Point:

## BLUETOOTH DONGLE FOR NOX A1S SUPPORT

Type	Catalog Number
Bluetooth® 5.0 dongle	544030

## SWITCHES, IP CAMERAS AND MICROPHONES

Type	Catalog Number
Trendnet PoE Switch	NA

## CONNECTION CABLES

Type	Catalog Number
Sinbon C1 Serial Cable	562013
Sinbon C1 Splitter Cable	562014
Sinbon C1 Extension cable	562012

\* The 3<sup>rd</sup> party FRIWO MP115 Medical-7555M/12 medical grade power supply has been validated with the Nox C1 Access point and is included in the C1 Kit. C1 Kit has the catalog number 544021

## AUXILIARY DEVICES SUPPORTED

Type	Catalog Number
SenTec SDM	NA
Radiometer TCM4/CombiM	NA
Radiometer TCM40/TCM TOSCA	NA
Nonin Respsense EtCO2 Monitor	NA
Resmed Airsense™10	NA
Resmed S9™	NA
Resmed Aircurve	NA
Masimo Radical-7 Tabletop Oximeter	NA
Nonin Model 7500 Tabletop Oximeter	NA

## DIFFERENTIAL PRESSURE SENSOR

Type	Catalog Number
Pneumoflow Sensor	552810

## CLEANING

Type	Catalog Number
PDI Sani-Cloth Plus Germicidal Disposable Cloth	NA

## SPECIFICATIONS

### Nox C1 Access Point

#### DESCRIPTION

#### PROPERTIES

##### FUNCTION

- Nox C1 Channels**
- ▶ Ambient Light Channel
  - ▶ Differential Pressure Channel
  - ▶ Twelve Analog Input Channels (DC)
  - ▶ Two USB Input Channels\*
  - ▶ Two Serial Input Channels

##### PHYSICAL

- Nox C1 Dimensions** ▶ 135 mm x 149 mm x 26 mm (5.3" x 5.9" x 1.0")
- Nox C1 Weight** ▶ 264 g (9.3 oz)
- Nox C1 DC Inputs**
- ▶ Number of Channels: 12
  - ▶ Number of Inputs: 6
  - ▶ Input Voltage Range:  $\geq \pm 5$  V
  - ▶ Sampling: 16 bit, 250 sample/s
  - ▶ Connector: 3.5 mm Female Stereo Jack
- Nox C1 Light Sensor Input**
- ▶ Light Range: Can distinguish between dark room and a slightly lit room
  - ▶ Sampling: 16 bit, 250 sample/s
- Nox C1 Light Indicator**
- ▶ Number of LEDs: 1
  - ▶ Colors: Green and Amber for status indication
- Nox C1 Pressure Sensor Input**
- ▶ Number of Channels: 1
  - ▶ Number of Inputs: 2
  - ▶ Absolute Maximum Input Pressure:  $> \pm 100$  cmH<sub>2</sub>O
  - ▶ Pressure Input Range:  $\geq \pm 40$  cmH<sub>2</sub>O
  - ▶ Sampling: 16 bit, 250 sample/s
  - ▶ Connector: Differential sensor port

---

\* Currently the USB ports do not have any function

- Nox C1 USB Inputs**
  - ▶ Number of Channels: 2
  - ▶ Number of Inputs: 2
  - ▶ USB 2.0 compliance
  - ▶ High Speed (up to 480 Mbit/s)
  - ▶ Connector: USB Type A
- Nox C1 Serial Inputs**
  - ▶ Number of Channels: 2
  - ▶ Number of Inputs: 2
  - ▶ RS-232
  - ▶ Connector: 3.5 mm Female Stereo Jack
  - ▶
  - ▶
  - ▶
  - ▶
  - ▶
  - ▶

**COMMUNICATION**

- Nox C1 Bluetooth®** ▶ Bluetooth® v.4.0
- Nox C1 Ethernet**
  - ▶ Number of Inputs: 1
  - ▶ 10/100 BASE-TX
  - ▶ Connector: RJ-45

**Power Supply**

DESCRIPTION	PROPERTIES
<b>Power Supply Model</b>	▶ FRIWO MP115 Medical-7555M/12
<b>Nominal Input Voltage</b>	▶ 100-240 V AC +/- 10%
<b>Nominal Input</b>	▶ 50-60 Hz
<b>Nominal Input Current</b>	▶ 0.350-0.150 Arms (at max load)
<b>Nominal Output Voltage</b>	▶ 12 V DC +/- 5%
<b>Nominal Output Current</b>	▶ 0-1250 mA

**Bluetooth® 5.0 Dongle**

DESCRIPTION	PROPERTIES
<b>Dongle Model</b>	▶ BL654
<b>Dongle Dimensions</b>	▶ 18.39 mm x 50.74 mm x 11 mm
<b>Dongle Supply Voltage</b>	▶ 5.0V +/- 10% Powered by standard USB port
<b>Dongle Bluetooth®</b>	▶ Bluetooth® v.5.0

For more information about the dongle, refer to [www.lairdconnect.com](http://www.lairdconnect.com).

## REGULATORY INFORMATION

### Performance Testing and Validation Summary

The Nox Sleep System has been tested and verified in various phases to include internal testing, verification, and validation as well as external testing to assure product safety, effectiveness, and reliability. The design was verified and validated, throughout the design process, according to requirement specifications and intended use. External accredited test houses were used to conduct testing needed to comply with the applicable standards regarding Electromagnetic Compatibility (EMC) and patient safety as well as additional radio frequency (RF) testing to assure compliance with Federal Communications Commission (FCC).

Nox Medical holds an ISO 13485:2016 (MDSAP) certified Quality Management System which complies with the requirements of the Medical Device Directive (MDD - Council Directive 93/42/EEC as amended by Directive 2007/47/EC); Canada – Medical Devices Regulations – Part 1 – SOR 98/282; Australia – Therapeutic Goods (Medical Devices) Regulations, 2002, Schedule 3 Part 1 (excluding Part 1.6) – Full Quality Assurance Procedure; Japan – MHLW Ministerial Ordinance 169, Article 4 to Article 68; PMD Act and USA – 21 CFR 820, 21 CFR 803, 21 CFR 806, 21 CFR 807 – Subparts A to D.

### Nox C1 Classification



- ▶ Degree of protection against electric shock: The device is classified as **class II equipment** (see the symbol to the left).
- ▶ Powering of the device: The device is powered from an **external electrical power source**.
- ▶ Degree of protection against harmful ingress of liquids and particulate matter: The Nox C1 Access Point is classified **IP20**, i.e., as defined by the standard IEC 60529 it is protected against solid foreign objects of 12,5 mm diameter and greater, but it is not protected against harmful ingress of liquids.
- ▶ Method of sterilization: The device is **NOT delivered sterile or intended to be sterilized**.
- ▶ Suitability for use in an oxygen rich environment: The device is **NOT intended for use in an oxygen rich environment**.
- ▶ Suitability for use with flammable agents and anesthetics: The device is **NOT intended for use in conjunction with flammable agents or with flammable anesthetic mixture with air or with oxygen or nitrous oxide**.
- ▶ Mode of operation: The device is intended for **continuous operation**.

### Description of Symbols and Labels



- ▶ Operating instructions / Consult instructions for use



- ▶ Caution



- ▶ Manufacturer information



- ▶ Date of manufacture



- ▶ Serial number

(01)15694311111498(11)YYMM  
DD(21)931XXXXXX

- ▶ Unique Device Identifier (UDI); the Application Identifier (01) represents the device identifier (DI) (“15694311111498”), the Application Identifier (11) the production date/date of manufacture (“YYMMDD”, with “YY” the last two digits of the production year, “MM” the production month and “DD” the production day), and the Application Identifier (21) the serial number of the device (“931XXXXXX”)



- ▶ Unique Device Identifier (UDI) presented in data matrix format



- ▶ Class II equipment



- ▶ Non-ionizing radiation. The equipment includes a RF transmitter: interference may occur in the vicinity of equipment marked with this symbol



- ▶ Bluetooth® wireless technology



- ▶ Federal Communications Commission (FCC) logo



- ▶ Keep dry



- ▶ Fragile, handle with care

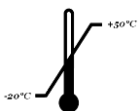

- ▶ Temperature limit



- ▶ Humidity limitation

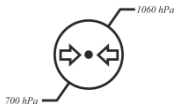

- ▶ Atmospheric pressure limitation



- ▶ Unsafe for MR (Magnetic Resonance) Environment.

**Contains FCC ID: QOQBT111**

- ▶ Federal Communications Commission (FCC) ID label

**DC IN 1-12**

- ▶ Analog inputs (DC)

**LAN**

- ▶ Ethernet cable input

**USB**

- ▶ USB inputs (currently nonfunctional)

**1 COM 2**

- ▶ Serial inputs

**+ PRES .**

- ▶ Differential pressure sensor inputs



- ▶ DC power supply connector



## Bluetooth® Wireless Technology

The Nox C1 Access Point uses Bluetooth® 4.0 wireless technology to communicate with external Bluetooth modules.

The Bluetooth wireless technology is based on a radio link that offers fast and reliable transmission of data. Bluetooth radio uses globally available frequency range in the industrial, scientific, and medical (ISM) band, intended to ensure communication compatibility worldwide and a fast acknowledgement and frequency-hopping scheme to make the link robust, even in noisy radio environments. Please refer to the “Specifications” section for details on Radio Frequency (RF) specifications for the Nox C1 Access Point.

The *Bluetooth*® word mark and logos are registered trademarks owned by the Bluetooth SIG, Inc. and any use of such marks by Nox Medical is under license. Other trademarks and trade names are those of their respective owners.

## Electromagnetic Compatibility (EMC) Information



- ▶ Note: Portable and mobile RF communications can affect the performance of the Nox C1 Access Point.
- ▶ Warning: Portable RF communications equipment (including peripherals such as antenna cables and external antennas) should be used no closer than 30 cm (12 inches) to any part of the Nox Sleep System, including cables specified by the manufacturer. Otherwise, degradation of the performance of this equipment could result.
- ▶ Warning: Electromagnetic interference (EMI) can be picked up by the analog and/or serial channels of the Nox C1 Access point, causing disturbed or altered signals to appear in the Noxturnal US software. This may affect data analysis and result in possible incorrect treatment.
- ▶ Warning: The Nox C1 Access Point(s) should not be used adjacent to or stacked with other equipment. If adjacent or stacked use is necessary, the device(s) should be observed to verify normal operation in the configuration in which it will be used and prevent abnormal operation which might cause injuries to the operator/patient.
- ▶ Warning: The use of accessories, transducers, sensors, and cables other than those listed in this manual could result in increased electromagnetic emissions or decreased electromagnetic immunity of the Nox Sleep System and result in improper operation.
- ▶ Warning: The Nox Sleep System may be interfered with by other equipment, even if that equipment complies with CISPR (Special International Committee on Radio Interference) emission requirements, causing possible patient harm.
- ▶ Refer to the tables below in this section for specific information regarding the Nox C1 Access Point’s compliance to the standard IEC60601-1-2: Medical electrical equipment - Part 1-2: General requirements for basic safety and essential performance - Collateral Standard: Electromagnetic disturbances - Requirements and tests.
- ▶ Warning: The minimum distance between the user and/or any bystander and the radiating structure of the Bluetooth® Dongle is 20 cm.

## Declarations of Conformity with the US Federal Communications Commission (FCC)

---



- ▶ Caution: Any changes or modifications to the equipment not expressly approved by Nox Medical could void user's authority to operate the equipment.

### NOX C1 ACCESS POINT

---

The device complies with Part 15 of the FCC Rules. Operation is subject to the following two conditions:

1. This device may not cause harmful interference, and
2. This device must accept any interference, including interference that may cause undesired operation of this device.

### BLUETOOTH® 5.0 DONGLE

---

This device complies with Industry Canada license-exempt RSS standard(s). Operation is subject to the following two conditions:

- (1) this device may not cause interference, and
- (2) this device must accept any interference, including interference that may cause undesired operation of the device.

### FCC RF Radiation Exposure Statement:

This equipment complies with FCC radiation exposure limits set forth for an uncontrolled environment. End users must follow the specific operating instructions for satisfying RF exposure compliance. This transmitter meets both portable and mobile limits as demonstrated in the RF Exposure Analysis and should not be used closer than 5 mm from a human body in portable configuration. This transmitter must not be co-located or operating in conjunction with any other antenna or transmitter except in accordance with FCC multi-transmitter product procedures.

### COMPLIANCE WITH FCC REGULATIONS

---

- The antenna(s) must be installed such that a minimum separation distance of 5 mm is maintained between the radiator (antenna) and all persons at all times.
- The transmitter module must not be co-located or operating in conjunction with any other antenna or transmitter except in accordance with FCC multi-transmitter product procedures.

### MODIFICATION STATEMENT

---

Any changes or modifications not expressly approved by Nox Medical could void the user's authority to operate the equipment.

Compliance to the standard IEC 60601-1-2: Medical electrical equipment - Part 1-2: General requirements for basic safety and essential performance - Collateral Standard: Electromagnetic disturbances - Requirements and Tests.

**ELECTROMAGNETIC EMISSIONS**

<p>The Nox C1 Access Point is intended for use in the electromagnetic environment specified below. The customer or the user of the device should assure that it is used in such an environment.</p>		
<b>Emissions test</b>	<b>Compliance</b>	<b>Electromagnetic environment – guidance</b>
RF emissions CISPR 11	Group 2	<p>The device is suitable for use in all establishments, including domestic establishments and those directly connected to the public low-voltage power supply network that supplies buildings used for domestic purposes.</p>
RF emissions CISPR 11	Class B	
Harmonic emissions IEC 61000-3-2	Class A	
Voltage fluctuations/ flicker emissions IEC 61000-3-3	Complies	

## ELECTROMAGNETIC IMMUNITY

The Nox C1 Access Point is intended for use in the electromagnetic environment specified below. The customer or the user of the device should assure that it is used in such an environment.

Immunity test	IEC 60601 test level	Compliance level
Electrostatic discharge (ESD) IEC 61000-4-2	±8 kV contact ±2 kV, ±4 kV, ±8 kV and ±15 kV air	±8 kV contact ±2 kV, ±4 kV, ±8 kV and ±15 kV air
Electrical fast transient/burst IEC 61000-4-4	± 2 kV for power supply lines ± 1 kV for input/output parts port 100 kHz repetition frequency	± 2 kV for A.C. power port ± 1 kV for input/output parts port 100 kHz repetition frequency
Surge IEC 61000-4-5	±0,5 kV, ±1 kV line-to-line ±0,5 kV, ±1 kV, ±2 kV lines-to- ground	±0,5 kV, ±1 kV and ±2 kV
Voltage dips IEC 61000-4-11	0 % $U_T$ for 0,5 cycle at 0°, 45°, 90°, 135°, 180°, 225°, 270° and 315°. 0 % $U_T$ for 1 cycle 70 % $U_T$ for 25/30 cycles	A.C. power port: 0 % $U_T$ for 0,5 cycle at 0°, 45°, 90°, 135°, 180°, 225°, 270° and 315°. 0 % $U_T$ for 1 cycle 70 % $U_T$ for 25/30 cycles
Voltage Interruptions IEC 61000-4-11	0 % $U_T$ for 250/300 cycles	A.C. power port: 0 % $U_T$ for 250/300 cycles
Rated power frequency magnetic field IEC 61000-4-8	30 A/m 50 or 60 Hz	30 A/m 60 Hz
Conducted disturbances induced by RF fields IEC 61000-4-6	3 V 0,15 MHz to 80 MHz 6 V in ISM and amateur radio bands between 0,15 MHz and 80 MHz 80% AM at 1 kHz	3 V 0,15 MHz to 80 MHz 6 V in ISM and amateur radio bands between 0,15 MHz and 80 MHz 80% AM at 1 kHz
Radiated RF EM fields IEC 61000-4-3	3 V/m and 10 V/m 80 MHz to 2.7 GHz 80% AM at 1 kHz	3 V/m and 10 V/m 80 MHz to 2.7 GHz 80% AM at 1 kHz

---

Proximity fields from RF wireless communications equipment IEC 61000-4-3	Refer to IMMUNITY TO PROXIMITY FIELDS FROM RF WIRELESS COMMUNICATIONS EQUIPMENT section	Refer to IMMUNITY TO PROXIMITY FIELDS FROM RF WIRELESS COMMUNICATIONS EQUIPMENT section
NOTE $U_T$ is the a.c. mains voltage prior to application of the test level.		

## IMMUNITY TO PROXIMITY FIELDS FROM RF WIRELESS COMMUNICATIONS EQUIPMENT

The Nox C1 Access Point is intended for use in the electromagnetic environment specified below. The customer or the user of the device should assure that it is used in such an environment.

Test Frequency (MHz)	Band (MHz)	Service	Modulation	Maximum power (W)	Distance (m)	Immunity Test Level (V/m)	Compliance (Yes/No)
385	380-390	TETRA 400	Pulse modulation 18Hz	1,8	0,3	27	Yes
450	430-470	GMRS 460, FRS 460	FM ±5 kHz deviation 1 kHz sine	2	0,3	28	Yes
710	704-787	LTE Band 13, 17	Pulse modulation 217 Hz	0,2	0,3	9	Yes
745							
780							
810	800-960	GSM 800/900, TETRA 800, iDEN 820, CDMA 850, LTE Band 5	Pulse modulation 18 Hz	2	0,3	28	Yes
870							
930							
1720	1700-1990	GSM 1800; CDMA 1900; GSM 1900; DECT; LTE Band 1, 3, 4, 25; UMTS	Pulse modulation 217 Hz	2	0,3	28	Yes
1845							
1970							
2450	2400-2570	Bluetooth, WLAN, 802.11 b/g/n, RFID 2450, LTE Band 7	Pulse modulation 217 Hz	2	0,3	28	Yes
5240	5100-5800	WLAN 802.11 a/n	Pulse modulation 217 Hz	0,2	0,3	9	Yes
5500							
5785							